

Note: For Tactile Paving details ref. Dwg. KP0102

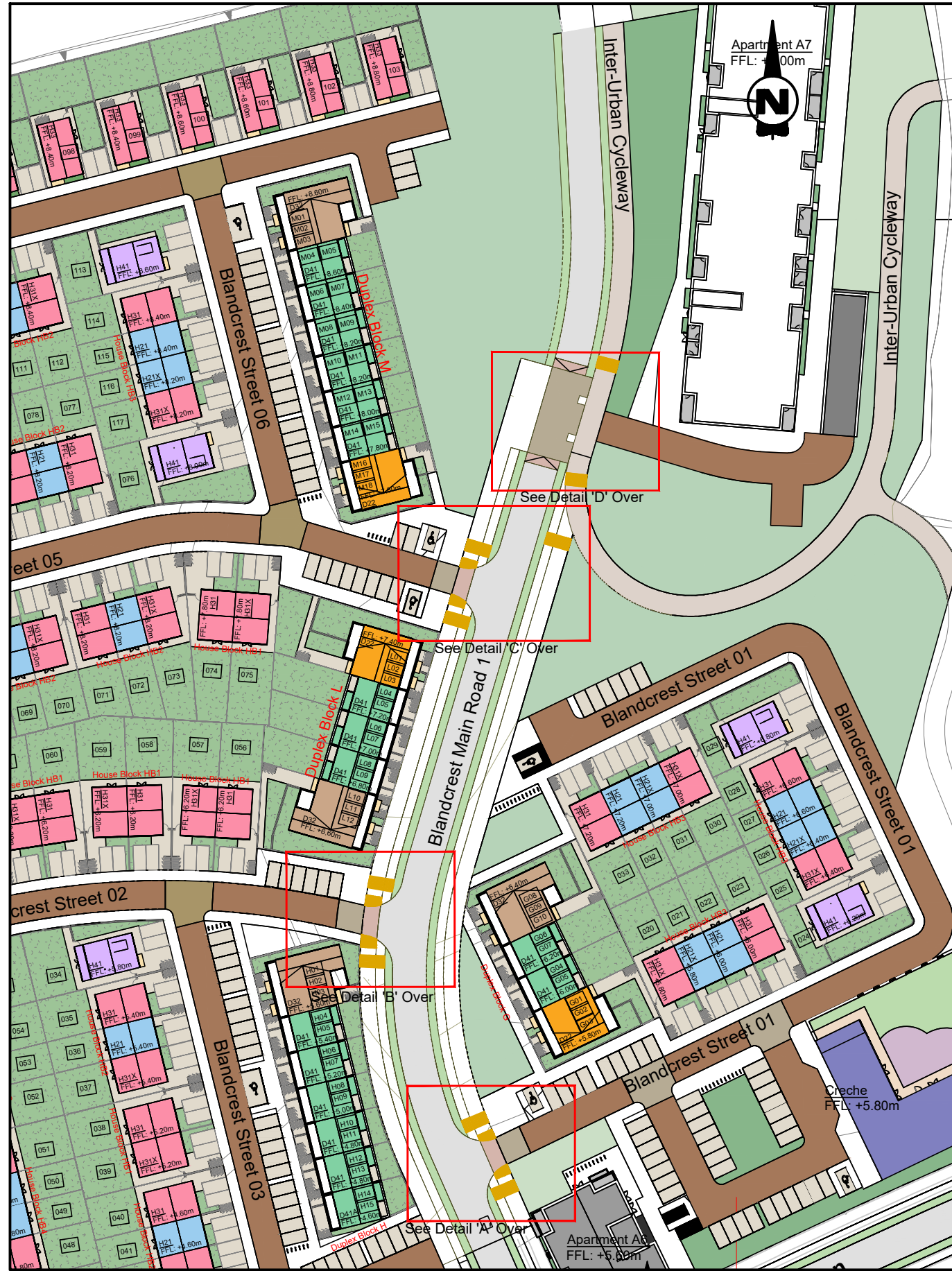

1:500 Layout Plan



Detail A  
(Scale 1 : 200)

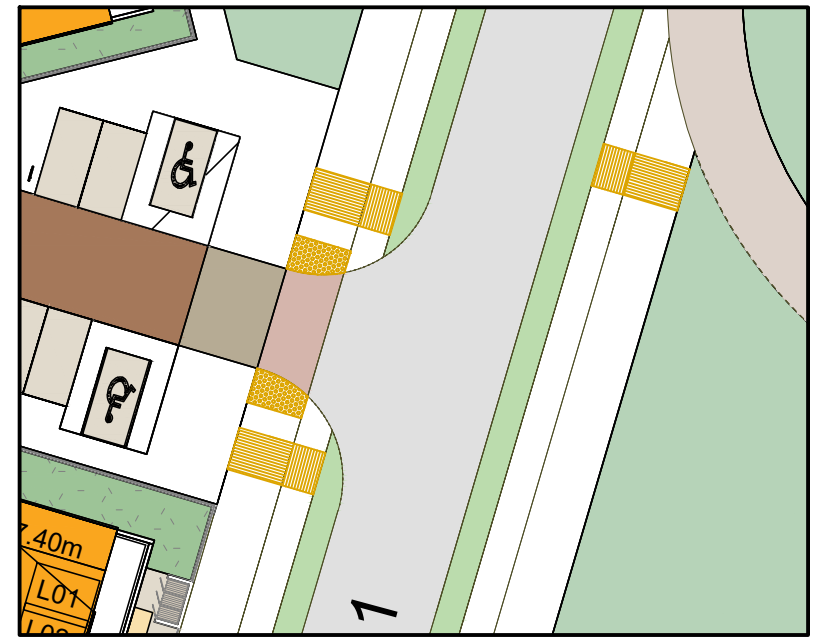

Detail C  
(Scale 1 : 200)

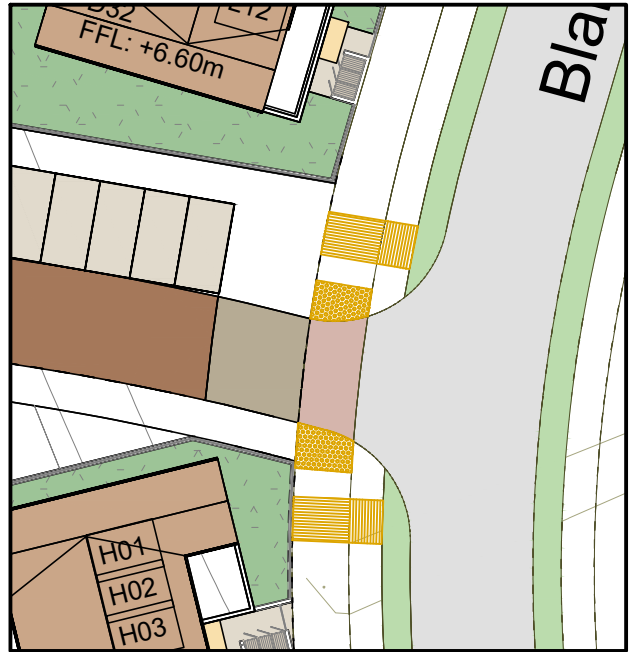

Detail B  
(Scale 1 : 200)



Detail D  
(Scale 1 : 200)

R:\MCW\1088 - BAM Castlelake Residential\DWG\1088-RPS-00-XX-DR-C-KP0101.dwg

Client



General Notes

(i) Hard copies, dwf and pdf will form a controlled issue of the drawing. All other formats (dwg etc.) are deemed to be an uncontrolled issue and any work carried out based on these files is at the recipient's own risk. RPS will not accept any responsibility for any errors from the use of these files, either by human error by the recipient, listing of the un-dimensioned measurements, compatibility with the recipient's software, and any errors arising when these files are used to aid the recipient's drawing production, or setting out on site.

(ii) DO NOT SCALE, use figured dimensions only.

(iii) This drawing is the property of RPS, it is a project confidential classified document. It must not be copied used or its contents divulged without prior written consent. The needs and expectations of client and RPS must be considered when working with this drawing.

(iv) Information including topographical survey, geotechnical investigation and utility detail used in the design have been provided by others.

(v) All Levels refer to Ordnance Survey Datum, Malin Head.

Rev	Date	Dim	Amendment / Issue	App
S4 P01	31/05/22	FOR CHECK	Issue for Planning	
S3 P01	23/05/22	FOR CHECK	Issue for Review and Comment	
P01	26/10/21	FOR CHECK	Pre-Planning Submission	

Model File Identifier	File Identifier	Status	Rev
MCW1088-RPS-00-XX-DR-C-KP0101	MCW1088-RPS-00-XX-DR-C-KP0101-01	S4	P01



Scale: 1:500 @ A1  
1:1000 @ A3

Created on: 24/10/2021

Sheets: 01 of 01

Project: Castlelake SHD

Title: Kerbs and Footways Tactile Paving Locations



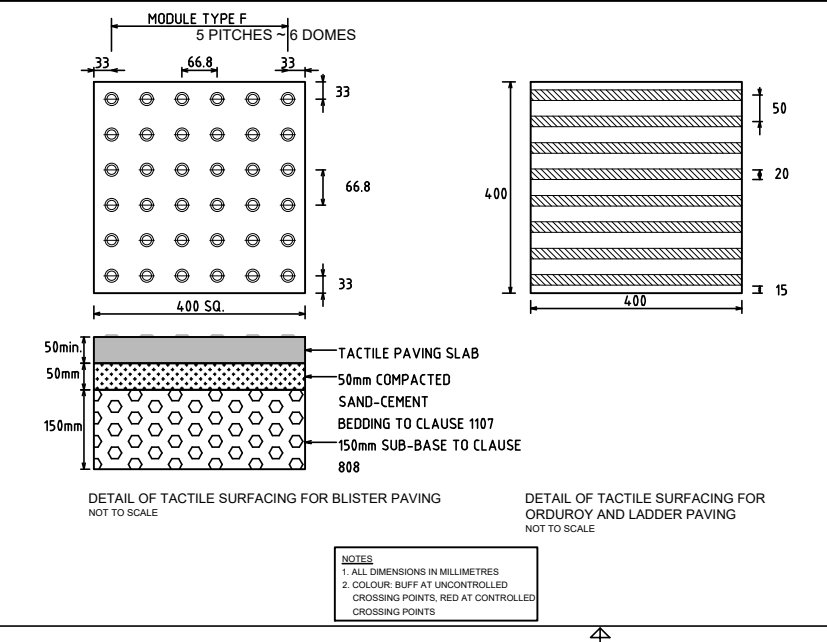
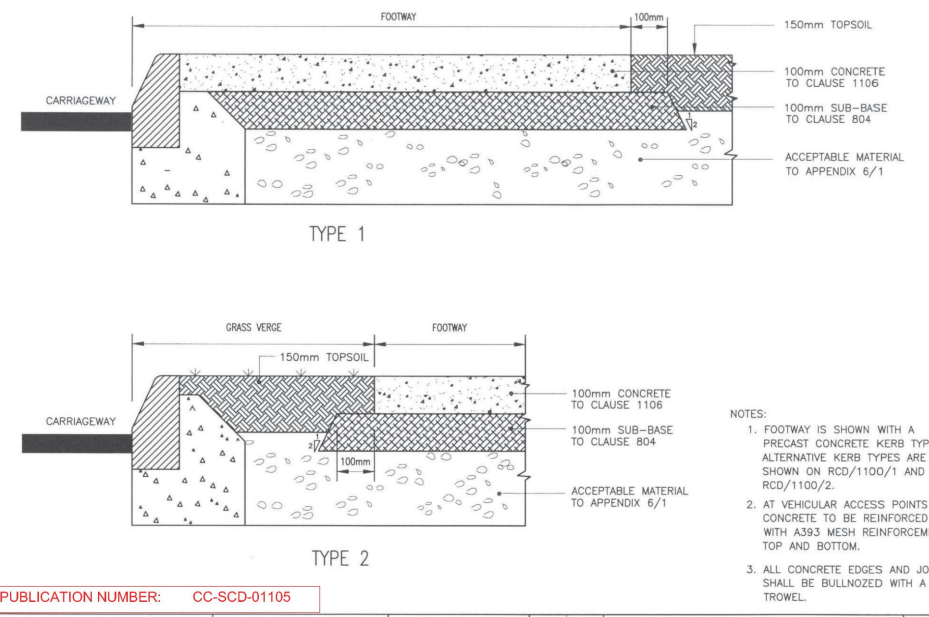
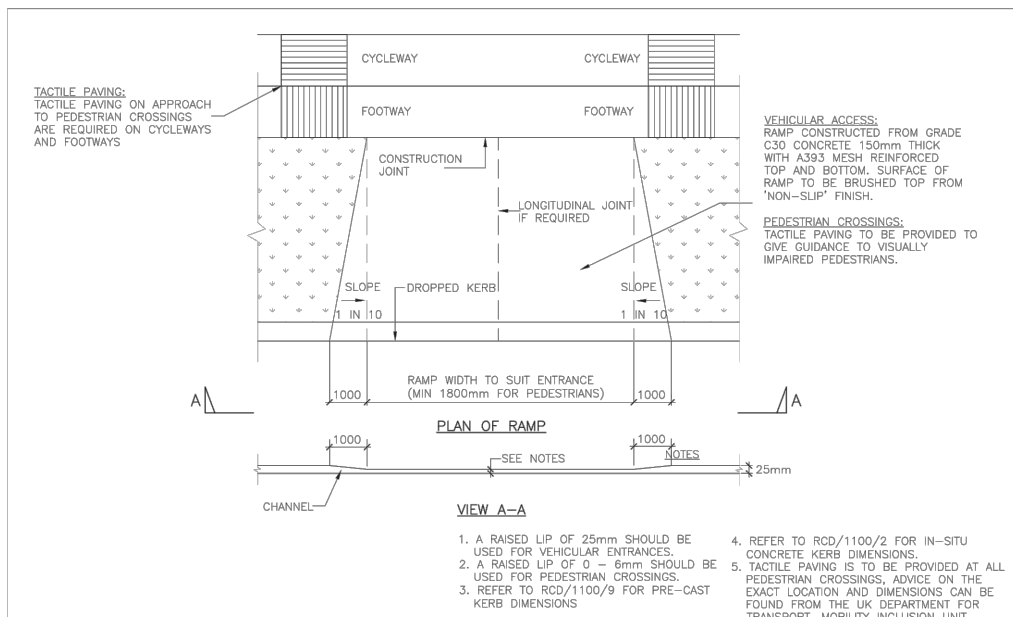

TII PUBLICATION NUMBER: CC-SCD-01103		Dropping No. RCD/1100/3	
NRA NATIONAL ROADS AUTHORITY	ROAD CONSTRUCTION DETAILS	KERBS, FOOTWAYS AND PAVED AREAS	P2 12/10
			P1 03/20
DROPPED KERB RAMP		Issue Date	

TII PUBLICATION NUMBER: CC-SCD-01105		Dropping No. RCD/1100/5	
NRA NATIONAL ROADS AUTHORITY	ROAD CONSTRUCTION DETAILS	KERBS, FOOTWAYS AND PAVED AREAS	P1 03/20
CONCRETE FOOTWAY		Issue Date	

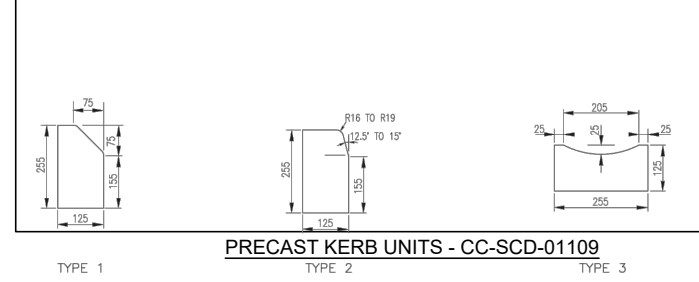
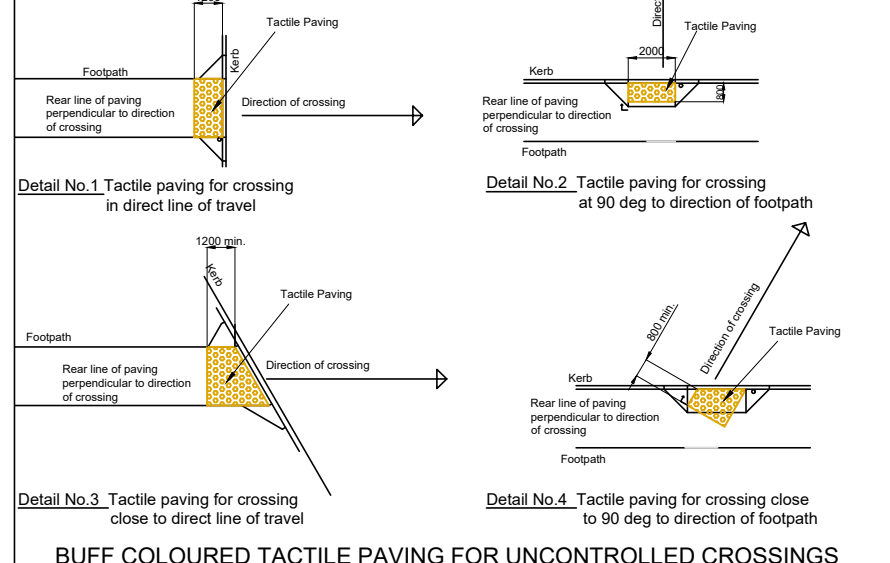
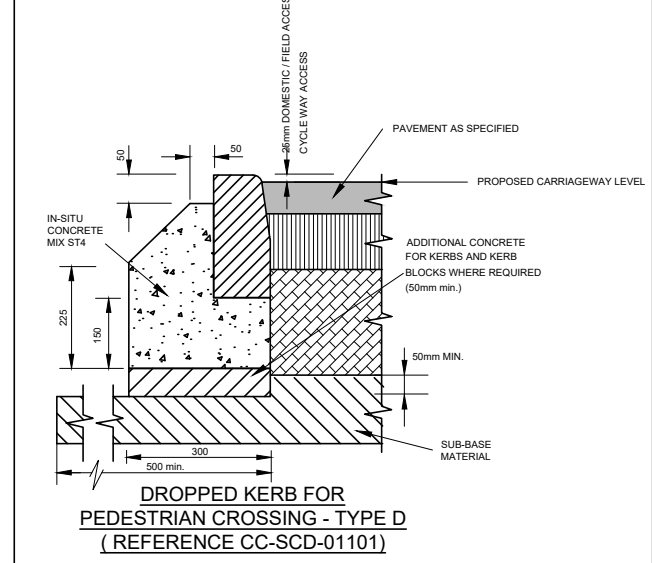
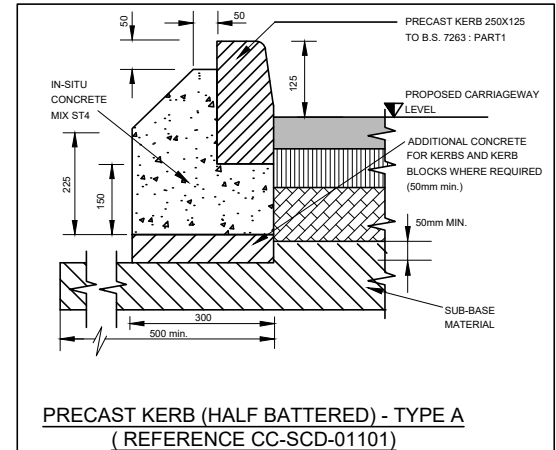
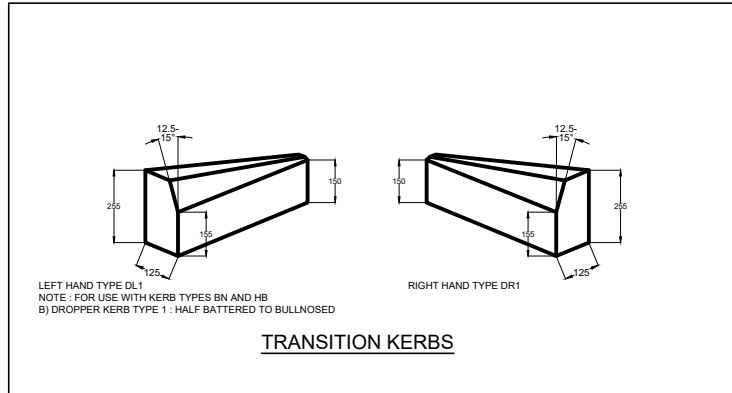

- Notes:
- Pavers shall be as detailed in the document - "Guidance on the use of tactile paving surfaces"
  - Pavers at uncontrolled crossings shall typically be of a buff colour or as otherwise approved by the Engineer.
  - Pavers at controlled crossings shall typically be of a red colour or as otherwise approved by the Engineer.
  - Tactile paving shall be in accordance with appendix 11/1.
  - Tactile paving slabs 400x400x50mm
  - The tactile domes on the tiles must be lined up to give the direction of travel in order to cross the road straight.
  - Tactile paving should extend the full width of the controlled crossing.
  - The top of the paver shall be flush with the top of the dropped kerbs, the top of any adjoining paved area or the ground level of any adjoining landscaped area.
  - Utility/service boxes should not be located in tactile paved areas where possible.
  - Any gullies in the crossing to be relocated.
  - All dimensions are in millimeters unless otherwise stated.

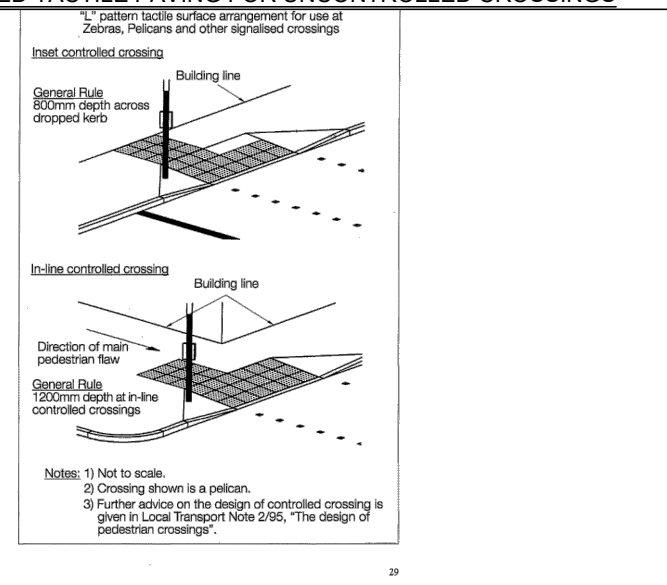
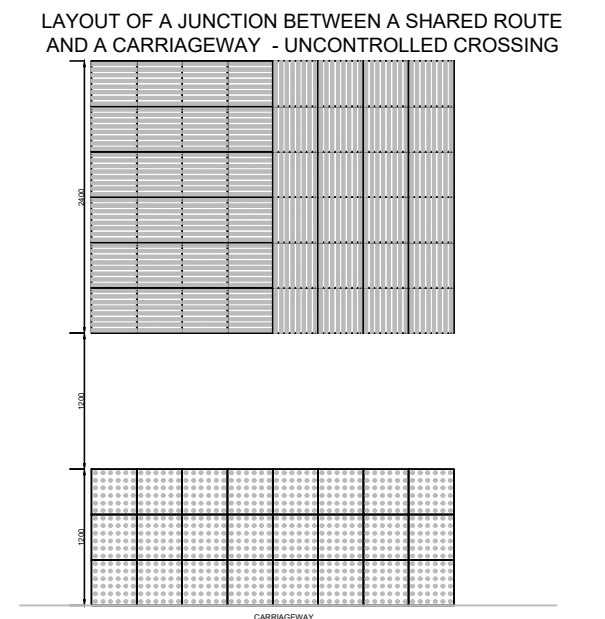
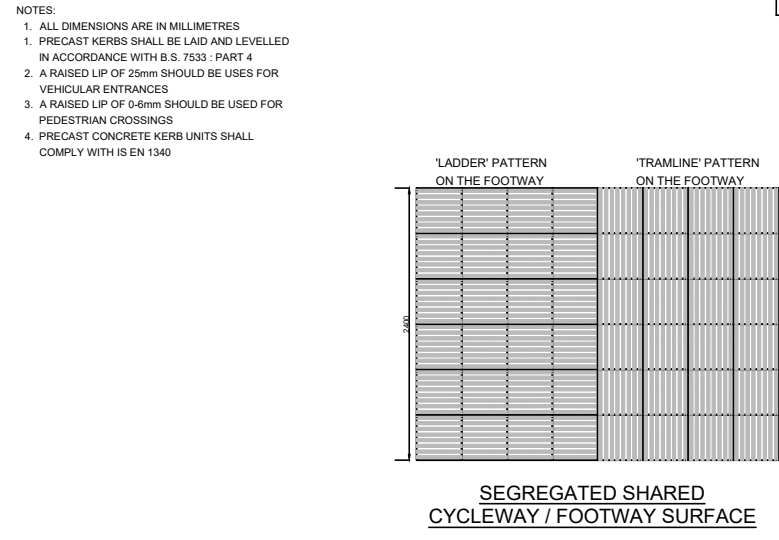

R:\MCW\088 - BAM Castlelake Residential Dwp\8.0 Drawings\KPI\MCW\088-RPS-00-XX-DR-C-KP0102.dwg



General Notes

(i) Hard copies, dwf and pdf will form a controlled issue of the drawing. All other formats (dwg etc.) are deemed to be an uncontrolled issue and any work carried out based on these files is at the recipient's own risk. RPS will not accept any responsibility for any errors from the use of these files, either by human error by the recipient, listing of the un-dimensioned measurements, compatibility with the recipient's software, and any errors arising when these files are used to aid the recipient's drawing production, or setting out on site.

(ii) DO NOT SCALE. Use figured dimensions only.

(iii) This drawing is the property of RPS, it is a project confidential document. It must not be copied used or its contents divulged without prior written consent. The needs and expectations of client and RPS must be considered when working with this drawing.

(iv) Information including topographical survey, geotechnical investigation and utility detail used in the design have been provided by others.

(v) All Levels refer to Ordnance Survey Datum, Malin Head.

Rev	Date	Drawn/Checked	Amendment / Issue	App
S4	P01	08/06/22	Issue for Planning	BP
S3	P01	23/05/22	Issue for Review and Comment	BP
P01		26/10/21	Pre-Planning Submission	BP



Scale	See Drg. @ A1 See Drg. @ A3	Project	Castlelake SHD
Created on	22/10/2021	Title	Kerbs & Footways Standard Details
Sheets	01 of 01	File Identifier	MCW1088-RPS-00-XX-DR-C-KP0102-01
Model File Identifier	MCW1088-RPS-00-XX-DR-C-KP0102	Status	S4
Rev	P01	Rev	P01